



Design Award . . . .

## LW Series Control Units

### L6/A6 Series Accessories

Flush bezel **height 2 mm** from the front of the panel



Accessories available for **L6/A6** series control units



# Add Style to Your Panel



## LW Series Flush Silhouette Control Units

Shape	Bezel Size	Bezel Material	Panel Cut-out	Lens Type	Pushbutton	Pilot Light	Illuminated Pushbutton
	ø28	Metal	ø25.3	Flush	<input type="checkbox"/>	<input type="checkbox"/>	<input type="checkbox"/>
				Extended	<input type="checkbox"/>	<input type="checkbox"/>	<input type="checkbox"/>
	ø28	Plastic	ø25.3	Flush	<input type="checkbox"/>	<input type="checkbox"/>	<input type="checkbox"/>
				Extended	<input type="checkbox"/>	<input type="checkbox"/>	<input type="checkbox"/>
	□28	Plastic	□24.5	Flush	<input type="checkbox"/>	<input type="checkbox"/>	<input type="checkbox"/>
				Extended	<input type="checkbox"/>	<input type="checkbox"/>	<input type="checkbox"/>

# Slimmer than Ever

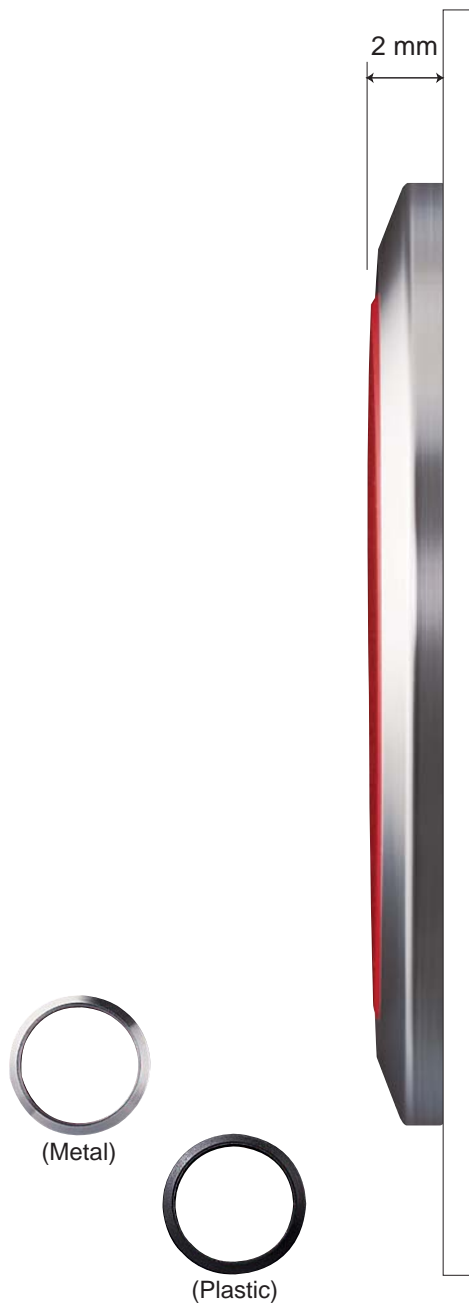

## L6/A6 Series Flush Silhouette Bezels

Shape	Bezel Size	Bezel Material	Panel Cut-out	Series	Pushbutton	Pilot Light	Illuminated Pushbutton	Selector	Key Selector	Illuminated Selector	Others
	ø24	Metal	ø20.2	L6 (Separate Type)	●	●	●	●	●	●	● (Lever)
				A6 (Unibody Type)	●	●	●	●	●	●	●
	ø24	Plastic	ø20.2	L6 (Separate Type)	●	●	●	●	●	●	● (Lever)
				A6 (Unibody Type)	●	●	●	●	●	●	●
	□24	Plastic	□20.2	L6 (Separate Type)	●	●	●	●	●	●	
				A6 (Unibody Type)	●	●	●	●	●	●	●
	24 x 30	Plastic	20.2 x 26.2	L6 (Separate Type)	●	●	●	●	●	●	● (Buzzer)
				A6 (Unibody Type)	●	●	●	●	●	●	●





Note: For the L6 and A6 series, flush silhouette bezels are ordered separately to be combined with control units.

# Flush Silhouette LW series Control Units

Flush bezel projects only 2 mm from front of panel

Ø28 round and 28-mm square black plastic bezels. Round metallic bezels are also available.

- Ø25.3-mm round panel cut-out, 24.5-mm square panel cut-out.
- Collective mounting is possible.
- Separate type control units with a locking lever enable easy installation even when mounted collectively.
- Gold (gold-clad silver) or silver contacts.
- Degree of protection: IP65 (IEC 60529)
- UL and CSA approved. EN compliant.

Safety Standards	File No. or Organization
UL 	UL Recognition File No. E55996
CSA 	166730 (LR21451)
EN EN60947-1 EN60947-5-1	 TÜV Rheinland
	 EC Low Voltage Directive

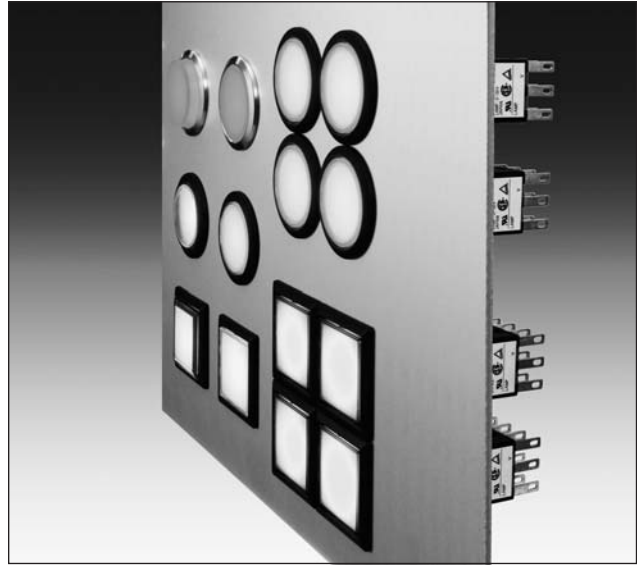

## Specifications and Ratings

### Contact Ratings

#### • Gold Contact

Maximum Voltage	250V AC/DC		
Thermal Current	3A		
Operating Voltage	30V DC	125V AC	
Operating Current (resistive load)	0.1A	0.1A	
Contact Material	Gold-clad silver		

Minimum applicable load (reference value): 5V AC/DC, 1mA  
(Applicable range is subject to the operating condition and load.)

#### • Silver Contact

Operating Voltage		30V	125V	250V	
Operating Current	AC 50/60Hz	Resistive Load	–	3A 2A	
		Inductive Load	–	2A 1.5A	
	DC	Resistive Load	2A	0.4A	–
		Inductive Load	1A	0.2A	–
Thermal Current		5A			
Contact Material		Silver			

AC inductive load: PF = 0.6 to 0.7

DC inductive load: L/R = 7 msec max.

### Specifications

Operating Temperature	–25 to +60°C (no freezing) Illuminated units: –25 to +50°C	
Storage Temperature	–40 to +80°	
Operating Humidity	45 to 85% RH (no condensation)	
Contact Resistance	50 mΩ maximum (initial value)	
Insulation Resistance	100 MΩ minimum (500V DC megger)	
Dielectric Strength	Switch Unit	Between live part and ground: 2,500V AC, 1 minute Between terminals of different poles: 2,500V AC, 1 minute Between terminals of the same poles: 1,000V AC, 1 minute
	Illumination Unit	Between live part and ground: 2,500V AC, 1 minute
Vibration Resistance	Operating extremes: 5 to 55 Hz, amplitude 0.5 mm	
Shock Resistance	Damage limits: 1,000 m/s <sup>2</sup> Operating extremes: 100 m/s <sup>2</sup>	
Mechanical Life (minimum operations)	Momentary:	1,000,000
	Maintained:	500,000
Electrical Life (minimum operations)	Momentary:	100,000 (*1)
	Maintained:	100,000 (*2)
	*1 Switching frequency 1,800 operations/h *2 Switching frequency 900 operations/h	
Degree of Protection	IP65 (IEC 60529)	
Terminal Style	Solder/tab terminal no. 110 PC board terminal Screw terminal	

# Flush Silhouette LW Series Control Units

## LED Lamp Ratings (LSTD Type)

Type No.	LSTD-6②		LSTD-1②	LSTD-2②
Lamp Base	BA9S/13			
Rated Voltage	6V AC/DC		12V AC/DC	24V AC/DC
Voltage Range	6V AC/DC $\pm 10\%$		12V AC/DC $\pm 10\%$	24V AC/DC $\pm 10\%$
Current Draw	AC	A, R, W, Y: 17 mA G, S: 8 mA	11 mA	11 mA
	DC	A, R, W, Y: 14 mA G, S: 5.5 mA	10 mA	10 mA
Color Code ②	A (amber), G (green), R (red), S (blue), W (white), Y (yellow)			
Lamp Base Color	Same as illumination color			
Voltage Marking	Die stamped on the base			
Life (reference value)	Approx. 50,000 hours (The luminance is reduced to 50% the initial intensity when used on complete DC.)			
Internal Circuit	A, R, W, Y			
	G, S			

## Mounting Hole Layout

### • Round Type

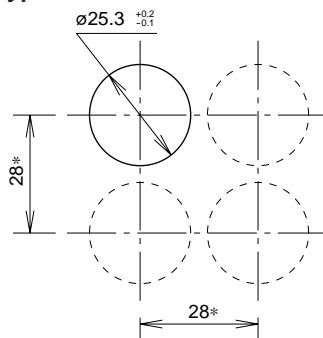

### • Square Type

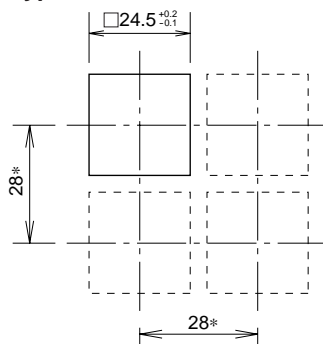

Note: Mounting centers should be determined to ensure easy operation.

\* Screw terminal type: Vertical 40 mm, Horizontal 26 mm minimum





## Ordering Information

### Standard Units

- Specify a button or lens color code in the Type No.
- All illuminated units are supplied with an LED lamp.
- All standard units are UL recognized, CSA certified, and EN compliant (TÜV Rheinland).

# Flush Silhouette LW Series Pushbuttons

## Flush Bezel (Round Metal Bezel) – Non-Illuminated

Shape	Operation Type	Contact Material	Contact	Type No.			① Button Color Code
				Solder/Tab Terminal	PC Board Terminal	Screw Terminal	
Round Flush with Metal Bezel LW6MB-M1 LW6MB-A1  	Momentary	Gold	SPDT	LW6MB-M1C1①	LW6MB-M1C1V①	–	Specify a button color code in place of ① in the Type No.  LA: amber LB: black LG: green LR: red LS: blue LW: white LY: yellow
			DPDT	LW6MB-M1C2②	LW6MB-M1C2V①	LW6MB-M1C2M①	
			3PDT	LW6MB-M1C3③	LW6MB-M1C3V①	–	
		Silver	SPDT	LW6MB-M1C5⑤	–	–	
			DPDT	LW6MB-M1C6⑥	–	LW6MB-M1C6M①	
			3PDT	LW6MB-M1C7⑦	–	–	
	Maintained	Gold	SPDT	LW6MB-A1C1①	LW6MB-A1C1V①	–	
			DPDT	LW6MB-A1C2②	LW6MB-A1C2V①	LW6MB-A1C2M①	
			3PDT	LW6MB-A1C3③	LW6MB-A1C3V①	–	
		Silver	SPDT	LW6MB-A1C5⑤	–	–	
			DPDT	LW6MB-A1C6⑥	–	LW6MB-A1C6M①	
			3PDT	LW6MB-A1C7⑦	–	–	
Round Extended with Metal Bezel LW6MB-M2 LW6MB-A2  	Momentary	Gold	SPDT	LW6MB-M2C1①	LW6MB-M2C1V①	–	
			DPDT	LW6MB-M2C2②	LW6MB-M2C2V①	LW6MB-M2C2M①	
			3PDT	LW6MB-M2C3③	LW6MB-M2C3V①	–	
		Silver	SPDT	LW6MB-M2C5⑤	–	–	
			DPDT	LW6MB-M2C6⑥	–	LW6MB-M2C6M①	
			3PDT	LW6MB-M2C7⑦	–	–	
	Maintained	Gold	SPDT	LW6MB-A2C1①	LW6MB-A2C1V①	–	
			DPDT	LW6MB-A2C2②	LW6MB-A2C2V①	LW6MB-A2C2M①	
			3PDT	LW6MB-A2C3③	LW6MB-A2C3V①	–	
		Silver	SPDT	LW6MB-A2C5⑤	–	–	
			DPDT	LW6MB-A2C6⑥	–	LW6MB-A2C6M①	
			3PDT	LW6MB-A2C7⑦	–	–	

• Lenses for illuminated pushbuttons are used for flush silhouette pushbuttons.  
 [Metal bezel types will be available in October 2005.]

## Dimensions

All dimensions in mm.

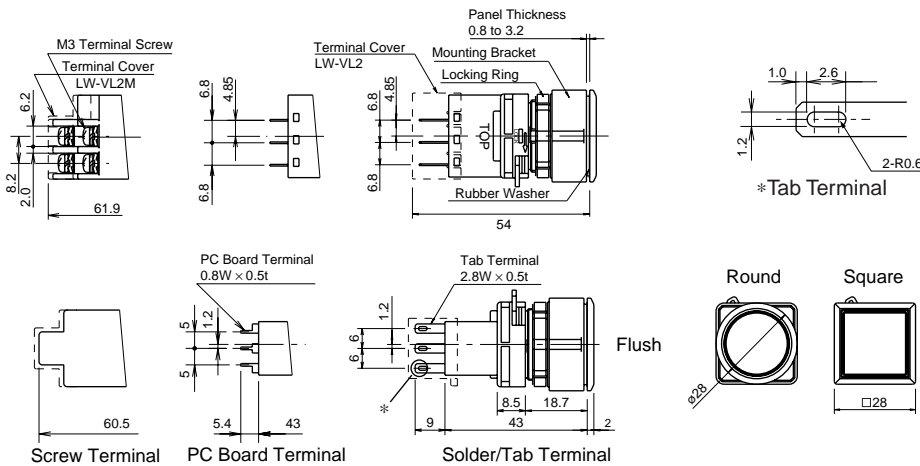

## Terminal Arrangement (Bottom View)

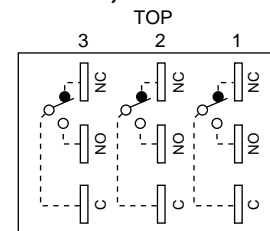

Note: SPDT has C, NO, and NC only in the center. DPDT has C, NO, and NC only on the right and left. Screw terminal type has only DPDT.

### Bottom View

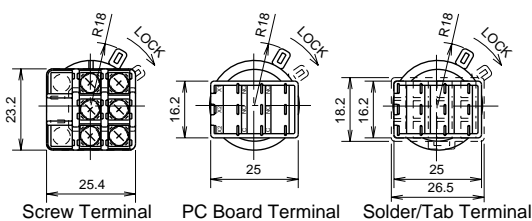







• For PC board dimensions, see page 7.



# Flush Silhouette LW Series Pushbuttons

## Flush Bezel (Round / Square Black Plastic Bezel) – Non-Illuminated

Shape	Operation Type	Contact Material	Contact	Type No.			① Button Color Code
				Solder/Tab Terminal	PC Board Terminal	Screw Terminal	
Round Flush with Black Plastic Bezel LW6B-M1 LW6B-A1  	Momentary	Gold	SPDT	LW6B-M1C1①	LW6B-M1C1V①	-	Specify a button color code in place of ① in the Type No.  LA: amber LB: black LG: green LR: red LS: blue LW: white LY: yellow
			DPDT	LW6B-M1C2②	LW6B-M1C2V①	LW6B-M1C2M①	
			3PDT	LW6B-M1C3③	LW6B-M1C3V①	-	
		Silver	SPDT	LW6B-M1C5⑤	-	-	
			DPDT	LW6B-M1C6⑥	-	LW6B-M1C6M①	
			3PDT	LW6B-M1C7⑦	-	-	
	Maintained	Gold	SPDT	LW6B-A1C1①	LW6B-A1C1V①	-	
			DPDT	LW6B-A1C2②	LW6B-A1C2V①	LW6B-A1C2M①	
			3PDT	LW6B-A1C3③	LW6B-A1C3V①	-	
		Silver	SPDT	LW6B-A1C5⑤	-	-	
			DPDT	LW6B-A1C6⑥	-	LW6B-A1C6M①	
			3PDT	LW6B-A1C7⑦	-	-	
Round Extended with Black Plastic Bezel LW6B-M2 LW6B-A2  	Momentary	Gold	SPDT	LW6B-M2C1①	LW6B-M2C1V①	-	
			DPDT	LW6B-M2C2②	LW6B-M2C2V①	LW6B-M2C2M①	
			3PDT	LW6B-M2C3③	LW6B-M2C3V①	-	
		Silver	SPDT	LW6B-M2C5⑤	-	-	
			DPDT	LW6B-M2C6⑥	-	LW6B-M2C6M①	
			3PDT	LW6B-M2C7⑦	-	-	
	Maintained	Gold	SPDT	LW6B-A2C1①	LW6B-A2C1V①	-	
			DPDT	LW6B-A2C2②	LW6B-A2C2V①	LW6B-A2C2M①	
			3PDT	LW6B-A2C3③	LW6B-A2C3V①	-	
		Silver	SPDT	LW6B-A2C5⑤	-	-	
			DPDT	LW6B-A2C6⑥	-	LW6B-A2C6M①	
			3PDT	LW6B-A2C7⑦	-	-	
Square Flush with Black Plastic Bezel LW7B-M1 LW7B-A1  	Momentary	Gold	SPDT	LW7B-M1C1①	LW7B-M1C1V①	-	
			DPDT	LW7B-M1C2②	LW7B-M1C2V①	LW7B-M1C2M①	
			3PDT	LW7B-M1C3③	LW7B-M1C3V①	-	
		Silver	SPDT	LW7B-M1C5⑤	-	-	
			DPDT	LW7B-M1C6⑥	-	LW7B-M1C6M①	
			3PDT	LW7B-M1C7⑦	-	-	
	Maintained	Gold	SPDT	LW7B-A1C1①	LW7B-A1C1V①	-	
			DPDT	LW7B-A1C2②	LW7B-A1C2V①	LW7B-A1C2M①	
			3PDT	LW7B-A1C3③	LW7B-A1C3V①	-	
		Silver	SPDT	LW7B-A1C5⑤	-	-	
			DPDT	LW7B-A1C6⑥	-	LW7B-A1C6M①	
			3PDT	LW7B-A1C7⑦	-	-	

• Lenses for illuminated pushbuttons are used for flush silhouette pushbuttons.  
 For dimensions, see page 6.

### PC Board Drilling Layout (Bottom View)

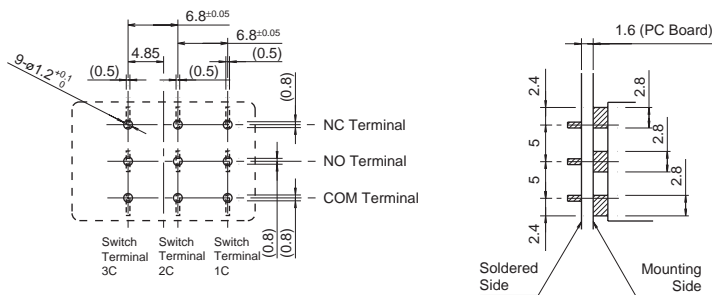













All dimensions in mm.

Pay attention to the pattern of the PC board as the terminals on the mounting surface are 2.8 mm wide.

# Flush Silhouette LW series Pilot Lights

## Flush Bezel (Round Metal / Plastic and Square Black Plastic Bezel) – LED Illuminated

Shape	Lamp	Input Type	Type No			② Lens Color Code
			Solder/Tab Terminal (Unibody Type)	PC Board Terminal (Separate Type)	Screw Terminal (Unibody Type)	
Round Flush with Metal Bezel LW6MP-1  	LED	6V AC/DC ±10%	LW6MP-12②	LW6MP-1C02V②	LW6MP-12M②	Specify a lens color code in place of ② in the Type No.  A: amber G: green R: red S: blue W: white Y: yellow
		12V AC/DC ±10%	LW6MP-13②	LW6MP-1C03V②	LW6MP-13M②	
		24V AC/DC ±10%	LW6MP-14②	LW6MP-1C04V②	LW6MP-14M②	
Round Extended with Metal Bezel LW6MP-2  	LED	6V AC/DC ±10%	LW6MP-22②	LW6MP-2C02V②	LW6MP-22M②	
		12V AC/DC ±10%	LW6MP-23②	LW6MP-2C03V②	LW6MP-23M②	
		24V AC/DC ±10%	LW6MP-24②	LW6MP-2C04V②	LW6MP-24M②	
Round Flush with Black Plastic Bezel LW6P-1  	LED	6V AC/DC ±10%	LW6P-12②	LW6P-1C02V②	LW6P-12M②	
		12V AC/DC ±10%	LW6P-13②	LW6P-1C03V②	LW6P-13M②	
		24V AC/DC ±10%	LW6P-14②	LW6P-1C04V②	LW6P-14M②	
Round Extended with Black Plastic Bezel LW6P-2  	LED	6V AC/DC ±10%	LW6P-22②	LW6P-2C02V②	LW6P-22M②	
		12V AC/DC ±10%	LW6P-23②	LW6P-2C03V②	LW6P-23M②	
		24V AC/DC ±10%	LW6P-24②	LW6P-2C04V②	LW6P-24M②	
Square Flush with Black Plastic Bezel LW7P-1  	LED	6V AC/DC ±10%	LW7P-12②	LW7P-1C02V②	LW7P-12M②	
		12V AC/DC ±10%	LW7P-13②	LW7P-1C03V②	LW7P-13M②	
		24V AC/DC ±10%	LW7P-14②	LW7P-1C04V②	LW7P-14M②	
Square Extended with Black Plastic Bezel LW7P-2  	LED	6V AC/DC ±10%	LW7P-22②	LW7P-2C02V②	LW7P-22M②	
		12V AC/DC ±10%	LW7P-23②	LW7P-2C03V②	LW7P-23M②	
		24V AC/DC ±10%	LW7P-24②	LW7P-2C04V②	LW7P-24M②	

[Metal bezel types will be available in October 2005.]

- Every pilot light contains an LED lamp (LSTD) of the specified color and voltage.



# Flush Silhouette LW series Pilot Lights

## Dimensions

### • Unibody Type

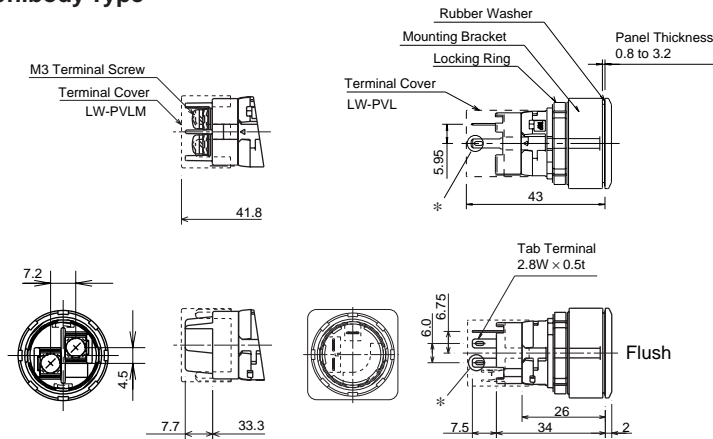

Screw Terminal

Solder/Tab Terminal

### • Separate Type

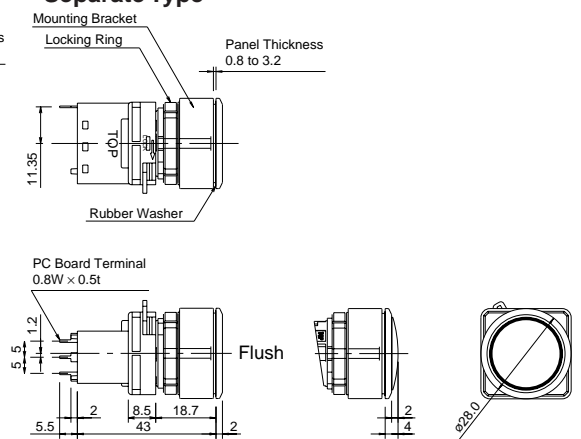

PC Board Terminal

Round (Extended)

Round

Square (Extended)

Square

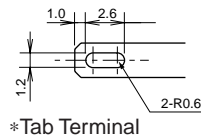

\*Tab Terminal

## Terminal Arrangement (Bottom View)

### • Unibody Type

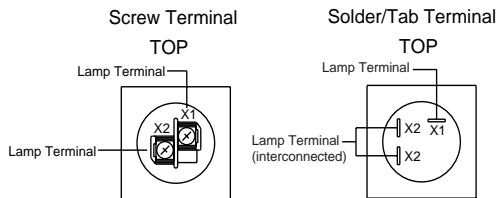

• Lamp terminals do not have any polarity.

### • Separate Type

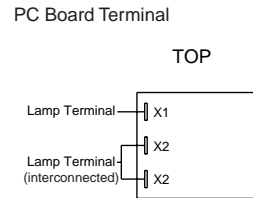

• Lamp terminals do not have any polarity.

## PC Board Drilling Layout (Bottom View)

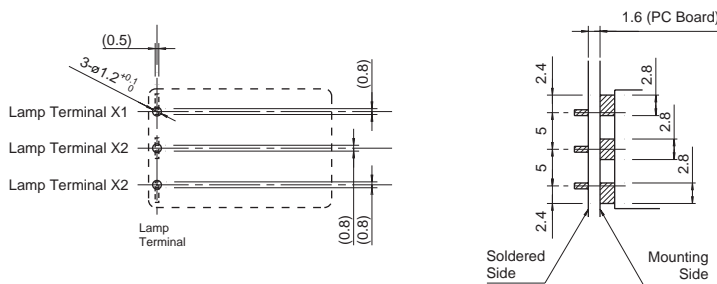





All dimensions in mm.

Pay attention to the pattern of the PC board as the terminals on the mounting surface are 2.8 mm wide.

# Flush Silhouette LW series Illuminated Pushbuttons

## Flush Bezel (Round Metal Bezel) – LED Illuminated

Shape	Lamp	Operation	Contact Material	Contact	Type No.		
					Solder/Tab Terminal	PC Board Terminal	Screw Terminal
Round Flush with Metal Bezel LW6ML-M1 LW6ML-A1  	LED	Momentary	Gold	SPDT	LW6ML-M1C1 <sup>③</sup> <sup>②</sup>	LW6ML-M1C1 <sup>③</sup> V <sup>②</sup>	–
				DPDT	LW6ML-M1C2 <sup>③</sup> <sup>②</sup>	LW6ML-M1C2 <sup>③</sup> V <sup>②</sup>	LW6ML-M1C2 <sup>③</sup> M <sup>②</sup>
				3PDT	LW6ML-M1C3 <sup>③</sup> <sup>②</sup>	LW6ML-M1C3 <sup>③</sup> V <sup>②</sup>	–
			Silver	SPDT	LW6ML-M1C5 <sup>③</sup> <sup>②</sup>	–	–
				DPDT	LW6ML-M1C6 <sup>③</sup> <sup>②</sup>	–	LW6ML-M1C6 <sup>③</sup> M <sup>②</sup>
				3PDT	LW6ML-M1C7 <sup>③</sup> <sup>②</sup>	–	–
		Maintained	Gold	SPDT	LW6ML-A1C1 <sup>③</sup> <sup>②</sup>	LW6ML-A1C1 <sup>③</sup> V <sup>②</sup>	–
				DPDT	LW6ML-A1C2 <sup>③</sup> <sup>②</sup>	LW6ML-A1C2 <sup>③</sup> V <sup>②</sup>	LW6ML-A1C2 <sup>③</sup> M <sup>②</sup>
				3PDT	LW6ML-A1C3 <sup>③</sup> <sup>②</sup>	LW6ML-A1C3 <sup>③</sup> V <sup>②</sup>	–
			Silver	SPDT	LW6ML-A1C5 <sup>③</sup> <sup>②</sup>	–	–
				DPDT	LW6ML-A1C6 <sup>③</sup> <sup>②</sup>	–	LW6ML-A1C6 <sup>③</sup> M <sup>②</sup>
				3PDT	LW6ML-A1C7 <sup>③</sup> <sup>②</sup>	–	–
Round Extended with Metal Bezel LW6ML-M2 LW6ML-A2  	LED	Momentary	Gold	SPDT	LW6ML-M2C1 <sup>③</sup> <sup>②</sup>	LW6ML-M2C1 <sup>③</sup> V <sup>②</sup>	–
				DPDT	LW6ML-M2C2 <sup>③</sup> <sup>②</sup>	LW6ML-M2C2 <sup>③</sup> V <sup>②</sup>	LW6ML-M2C2 <sup>③</sup> M <sup>②</sup>
				3PDT	LW6ML-M2C3 <sup>③</sup> <sup>②</sup>	LW6ML-M2C3 <sup>③</sup> V <sup>②</sup>	–
			Silver	SPDT	LW6ML-M2C5 <sup>③</sup> <sup>②</sup>	–	–
				DPDT	LW6ML-M2C6 <sup>③</sup> <sup>②</sup>	–	LW6ML-M2C6 <sup>③</sup> M <sup>②</sup>
				3PDT	LW6ML-M2C7 <sup>③</sup> <sup>②</sup>	–	–
		Maintained	Gold	SPDT	LW6ML-A2C1 <sup>③</sup> <sup>②</sup>	LW6ML-A2C1 <sup>③</sup> V <sup>②</sup>	–
				DPDT	LW6ML-A2C2 <sup>③</sup> <sup>②</sup>	LW6ML-A2C2 <sup>③</sup> V <sup>②</sup>	LW6ML-A2C2 <sup>③</sup> M <sup>②</sup>
				3PDT	LW6ML-A2C3 <sup>③</sup> <sup>②</sup>	LW6ML-A2C3 <sup>③</sup> V <sup>②</sup>	–
			Silver	SPDT	LW6ML-A2C5 <sup>③</sup> <sup>②</sup>	–	–
				DPDT	LW6ML-A2C6 <sup>③</sup> <sup>②</sup>	–	LW6ML-A2C6 <sup>③</sup> M <sup>②</sup>
				3PDT	LW6ML-A2C7 <sup>③</sup> <sup>②</sup>	–	–

### • Color Code and Voltage Code

② Lens/LED Color Code	③ Operating Voltage Code
Specify a Lens/LED color code in place of ② in the Type No. A: amber G: green R: red S: blue W: white Y: yellow	Specify an operating voltage code in place of ③ in the Type No. 2: 6V AC/DC 3: 12V AC/DC 4: 24V AC/DC

[Metal bezel types will be available in October 2005.]

- Every illuminated pushbutton contains an LED lamp (LSTD) of the specified color and voltage.

# Flush Silhouette LW series Illuminated Pushbuttons

## Flush Bezel (Round / Square Black Plastic Bezel) – LED Illuminated

Shape	Lamp	Operation	Contact Material	Contact	Type No.		
					Solder/Tab Terminal	PC Board Terminal	Screw Terminal
Round Flush with Black Plastic Bezel LW6L-M1 LW6L-A1  	LED	Momentary	Gold	SPDT	LW6L-M1C1③②	LW6L-M1C1③V②	–
				DPDT	LW6L-M1C2③②	LW6L-M1C2③V②	LW6L-M1C2③M②
				3PDT	LW6L-M1C3③②	LW6L-M1C3③V②	–
			Silver	SPDT	LW6L-M1C5③②	–	–
				DPDT	LW6L-M1C6③②	–	LW6L-M1C6③M②
				3PDT	LW6L-M1C7③②	–	–
		Maintained	Gold	SPDT	LW6L-A1C1③②	LW6L-A1C1③V②	–
				DPDT	LW6L-A1C2③②	LW6L-A1C2③V②	LW6L-A1C2③M②
				3PDT	LW6L-A1C3③②	LW6L-A1C3③V②	–
			Silver	SPDT	LW6L-A1C5③②	–	–
				DPDT	LW6L-A1C6③②	–	LW6L-A1C6③M②
				3PDT	LW6L-A1C7③②	–	–
Round Extended with Black Plastic Bezel LW6L-M2 LW6L-A2  	LED	Momentary	Gold	SPDT	LW6L-M2C1③②	LW6L-M2C1③V②	–
				DPDT	LW6L-M2C2③②	LW6L-M2C2③V②	LW6L-M2C2③M②
				3PDT	LW6L-M2C3③②	LW6L-M2C3③V②	–
			Silver	SPDT	LW6L-M2C5③②	–	–
				DPDT	LW6L-M2C6③②	–	LW6L-M2C6③M②
				3PDT	LW6L-M2C7③②	–	–
		Maintained	Gold	SPDT	LW6L-A2C1③②	LW6L-A2C1③V②	–
				DPDT	LW6L-A2C2③②	LW6L-A2C2③V②	LW6L-A2C2③M②
				3PDT	LW6L-A2C3③②	LW6L-A2C3③V②	–
			Silver	SPDT	LW6L-A2C5③②	–	–
				DPDT	LW6L-A2C6③②	–	LW6L-A2C6③M②
				3PDT	LW6L-A2C7③②	–	–
Round Flush with Black Plastic Bezel LW7L-M1 LW7L-A1  	LED	Momentary	Gold	SPDT	LW7L-M1C1③②	LW7L-M1C1③V②	–
				DPDT	LW7L-M1C2③②	LW7L-M1C2③V②	LW7L-M1C2③M②
				3PDT	LW7L-M1C3③②	LW7L-M1C3③V②	–
			Silver	SPDT	LW7L-M1C5③②	–	–
				DPDT	LW7L-M1C6③②	–	LW7L-M1C6③M②
				3PDT	LW7L-M1C7③②	–	–
		Maintained	Gold	SPDT	LW7L-A1C1③②	LW7L-A1C1③V②	–
				DPDT	LW7L-A1C2③②	LW7L-A1C2③V②	LW7L-A1C2③M②
				3PDT	LW7L-A1C3③②	LW7L-A1C3③V②	–
			Silver	SPDT	LW7L-A1C5③②	–	–
				DPDT	LW7L-A1C6③②	–	LW7L-A1C6③M②
				3PDT	LW7L-A1C7③②	–	–

### • Color Code and Voltage Code

② Lens/LED Color Code	③ Operating Voltage Code
Specify a Lens/LED color code in place of ② in the Type No. A: amber G: green R: red S: blue W: white Y: yellow	Specify an operating voltage code in place of ③ in the Type No. 2: 6V AC/DC 3: 12V AC/DC 4: 24V AC/DC

- Every illuminated pushbutton contains an LED lamp (LSTD) of the specified color and voltage.

# Flush Silhouette LW series Illuminated Pushbuttons

## Dimensions

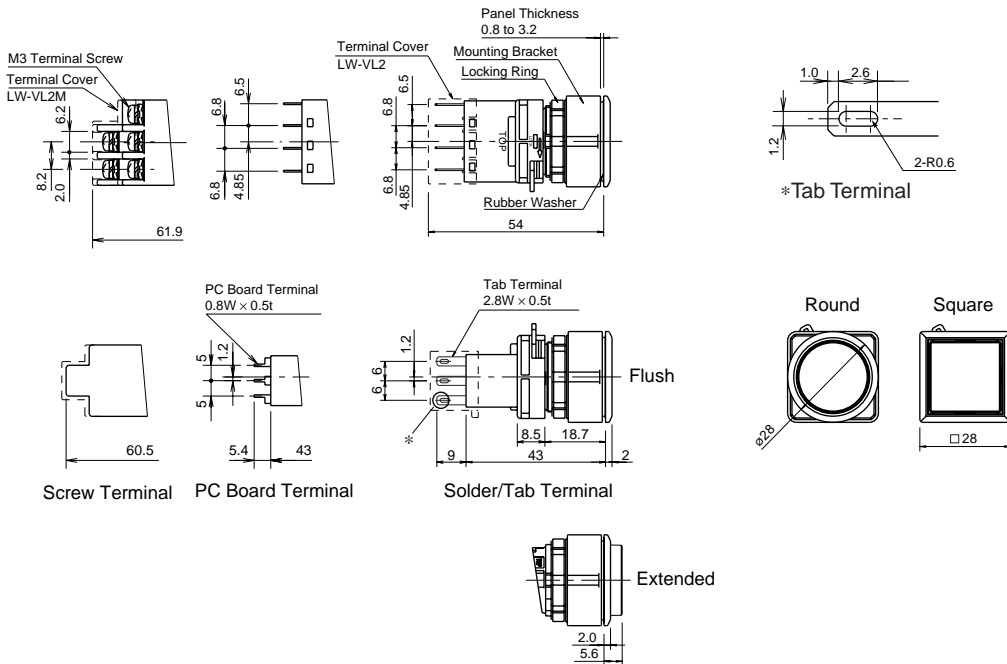

### • Bottom View

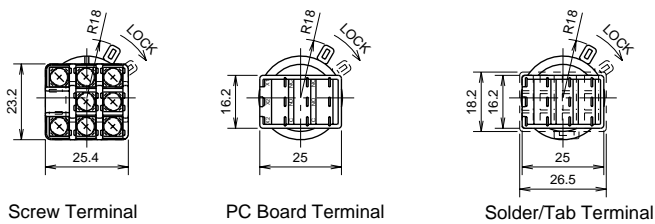

## Terminal Arrangement (Bottom View)

### • Solder/Tab Terminal

### • Screw Terminal

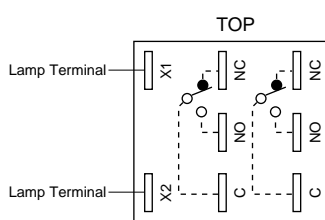
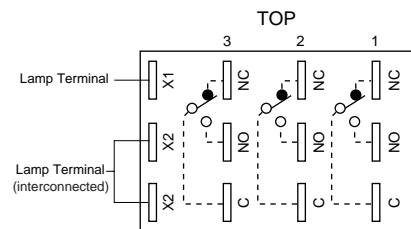

Note: SPDT has C, NO, and NC only in the center. DPDT has C, NO, and NC only on the right and left. Lamp terminals do not have any polarity.



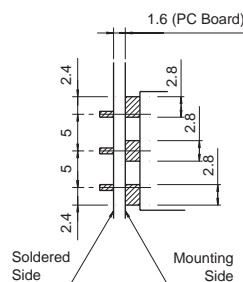
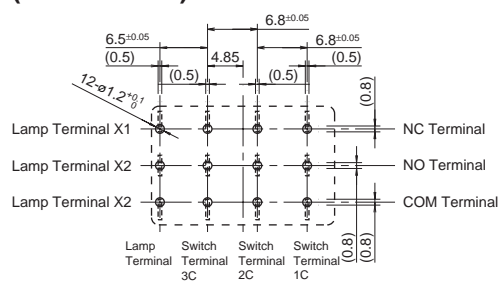







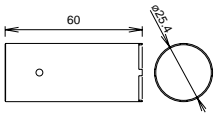

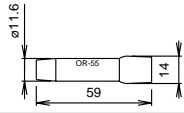

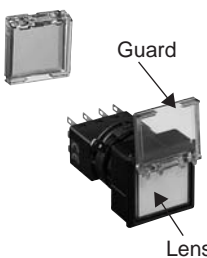
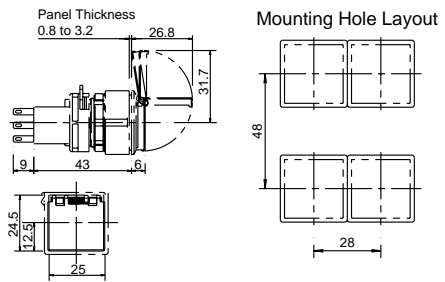

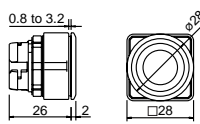
## PC Board Drilling Layout (Bottom View)

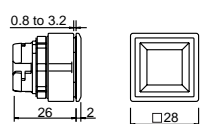

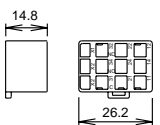
All dimensions in mm.

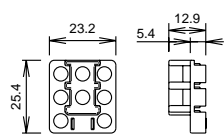

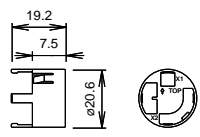

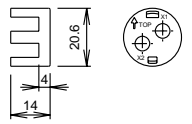



Pay attention to the pattern of the PC board as the terminals on the mounting surface are 2.8 mm wide.

# Flush Silhouette LW Series Accessories

Accessories				
Shape	Material	Type No. (Ordering Type No.)	Package Quantity	Dimensions (mm)
	Metal (nickel-plated brass)	LW9Z-T1	1	<ul style="list-style-type: none"> <li>Used to tighten the round bezel when installing the control unit onto a panel.</li> <li>Tightening Torque: 1.2 N·m</li> </ul> 
	Rubber	OR-55	1	<ul style="list-style-type: none"> <li>Used to install and remove LED/incandescent lamps.</li> </ul> 
	Rubber (Ring: metal)	MT-S01	1	<ul style="list-style-type: none"> <li>Used for removing the lens.</li> </ul>
Switch Guard with Lens (for Square Flush Lens) Spring Return Type 	Plastic (Guard: transparent)	LW9Z-KS7 <sup>Ⓜ</sup>	1	<ul style="list-style-type: none"> <li>Switch guard can be used by replacing with standard lens.</li> <li>Cannot be used with maintained types.</li> <li>Specify a lens color code in place of <sup>Ⓜ</sup> in the Type No. A: amber, C: clear, G: green, R: red, S: blue, Y: yellow</li> <li>Use a clear lens for white illumination or for white (LW) or black (LB) buttons.</li> </ul>  <p>Note: Determine mounting centers to ensure easy operation.</p>
	Plastic (black)	LW9Z-BS6	1	<ul style="list-style-type: none"> <li>Degree of protection: IP65</li> <li>Panel thickness: 0.8 to 3.2 mm</li> <li>See page 5 for mounting hole layout.</li> </ul> 
	Plastic (black)	LW9Z-BS7	1	<ul style="list-style-type: none"> <li>Degree of protection: IP65</li> <li>Panel thickness: 0.8 to 3.2 mm</li> <li>See page 5 for mounting hole layout.</li> </ul> 
	Plastic (translucent)	LW-VL2	1	<ul style="list-style-type: none"> <li>For separate type control unit only.</li> </ul> 
	Plastic (black)	LW-VL2M	1	<ul style="list-style-type: none"> <li>For separate type control unit only.</li> </ul> 
	Plastic (translucent)	LW-PVL	1	<ul style="list-style-type: none"> <li>For unibody type pilot lights only.</li> </ul> 
	Plastic (translucent)	LW-PVLM	1	<ul style="list-style-type: none"> <li>For unibody type pilot lights only.</li> </ul> 

# Flush Silhouette LW series Accessories



## Replacement Parts

Shape	Material	Type No.	Ordering Type No.	Package Quantity	Color Code	
Lens (Round Flush) 	Polyarylate	LW9Z-L1②	LW9Z-L1②PN05	5	Specify a lens color code in place of ② in the Ordering Type No.  A: amber C: clear G: green R: red S: blue Y: yellow  Note: Use a clear lens for white illumination or for white (LW) or black (LB) buttons.	
Lens (Round Extended) 	Polyarylate	LW9Z-L12②	LW9Z-L12②PN05	5		
Lens (Square Flush) 	Polyarylate	LW9Z-L2②	LW9Z-L2②PN05	5		
Lens for Pilot Lights (Round Extended) 	Polyarylate	LW9Z-L15②	LW9Z-L15②PN05	5		
Lens for Pilot Lights (Square Extended) 	Polyarylate	LW9Z-L25②	LW9Z-L25②PN05	5		
Marking Plate (Round) 	Acrylic	White	LW9Z-P1W	LW9Z-P1WPN05	5	• For round flush pushbuttons, round flush illuminated pushbuttons, and round extended pilot lights.
		Black	LW9Z-P1B	LW9Z-P1BPN05		
Marking Plate (Square) 	Acrylic	White	LW9Z-P2W	LW9Z-P2WPN05	5	• For square flush pushbuttons, square flush illuminated pushbuttons, and square extended pilot lights.
		Black	LW9Z-P2B	LW9Z-P2BPN05		
Marking Plate (Round Extended) 	Acrylic	White	LW9Z-P12W	LW9Z-P12WPN05	5	• For round extended pushbuttons and round extended illuminated pushbuttons.
		Black	LW9Z-P12B	LW9Z-P12BPN05		
Locking Ring 	Plastic	LW9Z-LN	LW9Z-LNPN05	5	• Black	

## LED Lamps

Operating Voltage	Current Draw		Type No.	Ordering Type No.	Illumination Color Code	Package Quantity	Base
	AC	DC					
6V AC/DC±10%	17 mA (A, R, W, Y) 8 mA (G, S)	14 mA (A, R, W, Y) 5.5 mA (G, S)	LSTD-6②	LSTD-6②	Specify a color code in place of ② in the Ordering Type No.	1	BA9S/13
				LSTD-6②PN10		10	
12V AC/DC±10%	11 mA	10 mA	LSTD-1②	LSTD-1②	A: amber G: green R: red S: blue W: white Y: yellow	1	
				LSTD-1②PN10		10	
24V AC/DC±10%	11 mA	10 mA	LSTD-2②	LSTD-2②	1		
				LSTD-2②PN10	10		

## Transformer

Separate Mounting Type	Primary Voltage	Secondary Voltage	Type No.	Applicable LED
For 6V 	100/110V AC	1W/5.5V AC	TWR516	LSTD-6②
	200/220V AC		TWR526	
	400/440V AC		TWR546	
For 24V 	100/110V AC	0.5W/24V AC	TWR512	LSTD-2②
	200/220V AC		TWR522	
	400/440V AC		TWR542	

- Terminal covers are included with separate mounting type transformers.
- Connect only one LSTD LED to separate mounting type transformers.



## Safety Precautions

- Turn off the power to the flush silhouette LW series control units before starting installation, removal, wiring, maintenance, and inspection of the products. Failure to turn power off may cause electrical shocks or fire hazard.
- To avoid burning your hand, use the lamp holder tool when replacing lamps.
- For wiring, use wires of a proper size to meet the voltage and current requirements. Solder correctly according to the instructions in "Wiring" and "Notes on Terminal Cover." Tighten the M3.5 terminal screws to a torque of 0.6 to 1.0 N·m. Failure to tighten terminal screws may cause overheating and fire.

## Instructions

### Panel Mounting

Remove the contact block from the operator. Insert the operator into the panel cut-out from the front, then install the contact block.

#### • Removing the Contact Block

Turn the locking lever on the contact block in the direction opposite to the arrow on the housing. Then the contact can be removed.

#### • Installing the Contact Block

Insert the contact block, with the TOP markings on the contact block and the operator placed in the same direction. Then lock the units, turning the locking lever in the direction of the arrow.

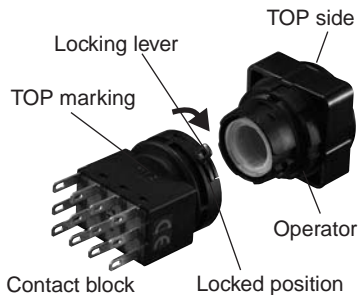

#### • Notes on Mounting

Use the optional ring wrench (LW9Z-T1) to mount the operator onto the panel. Tightening torque should not exceed 1.2 N·m. Do not use pliers. Excessive tightening will damage the locking ring.

#### • Collective Mounting

As the locking lever can be turned easily from the rear of the units using a screwdriver, the contact blocks can be removed even when mounted collectively.

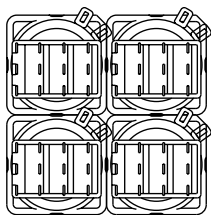

### Replacement of the Lens and Marking Plate

#### • Removing

1. To remove the lens unit, press the sucker of the optional lens removal tool (MT-S01) onto the lens and pull the lens unit.

[Removing the Lens Unit]



2. Remove the marking plate by pushing the lens from the rear to disengage the latches between the lens and the lens holder, using the screwdriver as shown below.

[Removing the lens]



Note: The translucent filter in the lens holder cannot be removed because the filter is sealed to make the unit watertight and oiltight.

#### • Installing

1. For round lens types, place the marking plate on the lens holder with the anti-rotation projection engaged and press the lens onto the lens holder to engage the latches. For square lens types, insert the marking plate into the lens, and press the lens onto the holder to engage the latches.
2. Make sure of correct orientation of the marking plate.

#### • Round Lens Type

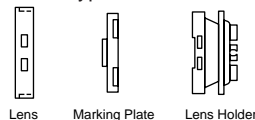

#### • Square Lens Type

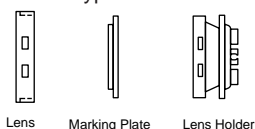

### Marking Plate and Films

For LW series illuminated pushbuttons and pilot lights, legends and symbols can be engraved on the marking plates, or printed film can be inserted under the lens for labelling purposes.

#### • Marking Plate and Marking Film Size

Lens	Round Lens	Square Lens
Built-in Marking Plate		
Applicable Marking Film		

• Engraving must be made on the engraving area within 0.5mm deep.  
• The marking plate is made of acrylic resin.

• Two 0.1mm-thick films or one 0.2mm-thick film can be installed in the lens.  
• Marking film is not included.  
• Recommended marking film: Polyester

#### • Insertion Order of Marking Plate and Film

##### • Round Lens Type

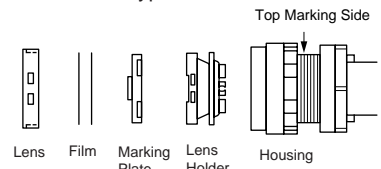

Note: Film is not included.

##### • Square Lens Type

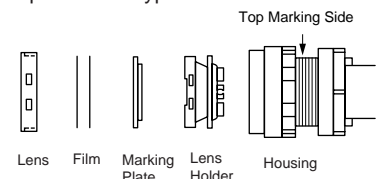

Note: Film is not included.

Make sure of correct orientation of the marking plate.

# Flush Silhouette LW series Instructions

## Instructions

### Replacement of Lamps

Lamps can be replaced using the lamp holder tool (OR-55) from the front of the panel, or by removing the contact block from the operator.

#### • How to Remove

To remove, slip the lamp holder tool onto the lamp head. Then push slightly, and turn the lamp holder tool counterclockwise.



Lamp Removal Tool  
OR-55



#### • How to Install

1. To install, insert the lamp head into the lamp holder tool, and hold the lamp as shown in the figure below.

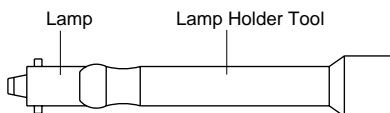

2. Insert the pins on the lamp base into the grooves in the lamp socket. Insert the lamp and turn it clockwise.

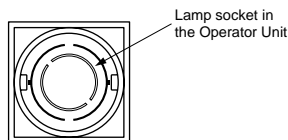

### Wiring

1. Solder the terminals within 20W/5 sec or 260°C/3 sec without exerting external force to the terminals. While soldering, do not touch the soldering iron to the housing. While wiring, prevent tension from being applied to the terminals. Do not bend or raise the terminals, nor exert excessive force to terminals.
2. Use non-corrosive liquid flux.
3. Positive-lock connector and easy-lock connectors are applicable to tab terminals.
4. Tighten the terminal screw of the screw terminal type to a torque of 0.6 to 1.0 N·m.

### Notes on Terminal Cover

[Solder/Tab Terminal]

Insert the terminal cover into the contact block with the TOP markings on the contact block and the terminal cover in the same direction.

Note: When wiring, insert the lead wires into the terminal cover holes before soldering.



#### • Notes on Wiring

When installing a terminal cover onto the solder/tab terminal contact block, solder the inside of lamp terminal (toward the switch terminals) and wire.

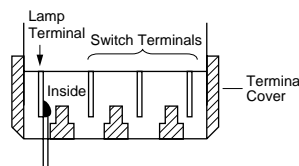

[Screw Terminal]

Terminal cover must be installed on the control unit before wiring.

Note 1: After wiring, terminal covers cannot be installed.

Note 2: When terminal covers are installed, do not use round crimping terminals.  
(Wire the terminals by using fork terminals or lead wires directly.)

### Single Board Mounting

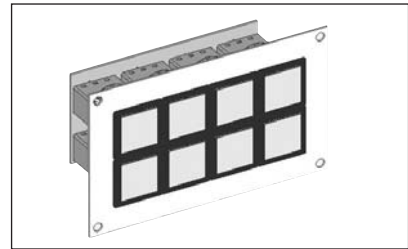

Mounting the control units on a single PC board offers the following features.

1. Reduced installation labor, easy wiring, space saving, and standardization.
2. Since the contact blocks on the PC board can be removed easily using a locking lever, control units are easy to maintain.
3. Because the control units require no studs for fastening the control unit to a PC board, special preparation of operation panel is not needed.
4. For details on single board mounting, contact IDEC.

# Flush Silhouette L6/A6 series Accessories

## New flush silhouette bezels for L6/A6 series ø16mm miniature control units

- Accessories for L6/A6 control units.
- Bezel Size
  - Round: ø24 mm (Panel Cut-out: ø20.2 mm)
  - Square: □24 mm (Panel Cut-out: □20.2 mm)
  - Rectangular: 24×30 mm (Panel Cut-out: 20.2×26.2 mm)

### • Applicable models

L6 Series	A6 Series
Illuminated Pushbutton	Illuminated Pushbutton
Pilot Light	Pilot Light
Pushbutton	Pushbutton
Selector Switch	Selector Switch
Key Selector Switch	Key Selector Switch
Illuminated Selector Switch	Illuminated Selector Switch
Lever Switch	
Buzzer	

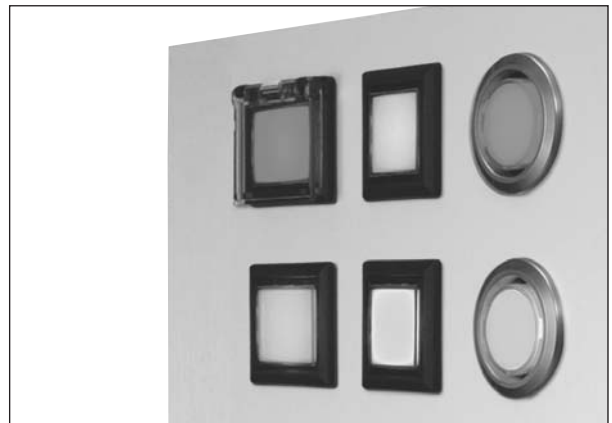

Note: Flush silhouette bezels cannot be used for mushroom buttons or lenses.

## Flush Bezel

Shape	Material	Type	Package Quantity	Remarks	
Round 	Metal (aluminium color)	LA9Z-SM61	1	<ul style="list-style-type: none"> <li>• Degree of Protection: IP65 (only when used with IP65 control units)</li> </ul>	
Round 	Plastic (black)	LA9Z-S61B	1		
Square 	Plastic (black)	LA9Z-S71B	1		
Rectangular 	Plastic (black)	LA9Z-S81B	1		
Switch Guard with Flush Bezel (Spring Return) Rectangular 	Plastic	LA9Z-KS8	1	<ul style="list-style-type: none"> <li>• Used for L6/A6 rectangular pushbuttons and illuminated pushbuttons. Cannot be used for selector switches, illuminated selector switches, and lever switches.</li> <li>• Degree of Protection: IP65 (only when used with IP65 control units)</li> </ul>	
Mounting Hole Plug	Round 	Plastic (black)	LA9Z-BS6	1	<ul style="list-style-type: none"> <li>• Degree of protection: IP65</li> </ul>
	Square 	Plastic (black)	LA9Z-BS7	1	
	Rectangular 	Plastic (black)	LA9Z-BS8	1	

Note: Terminal covers and maintenance parts for L6/A6 other than those shown above can also be used, except dust-proof covers.

[Metal type flush bezels (LA9Z-SM61) and switch guard with flush bezels (LA9Z-KS8) will be available in October 2005.]

# Flush Silhouette L6/A6 Series Accessories

## Ordering

- Control units are not supplied with flush bezels. Order flush bezels together with control units.

## Specifications

- Based on L6/A6 series control unit specifications.

## Dimensions

### • Flush Bezel

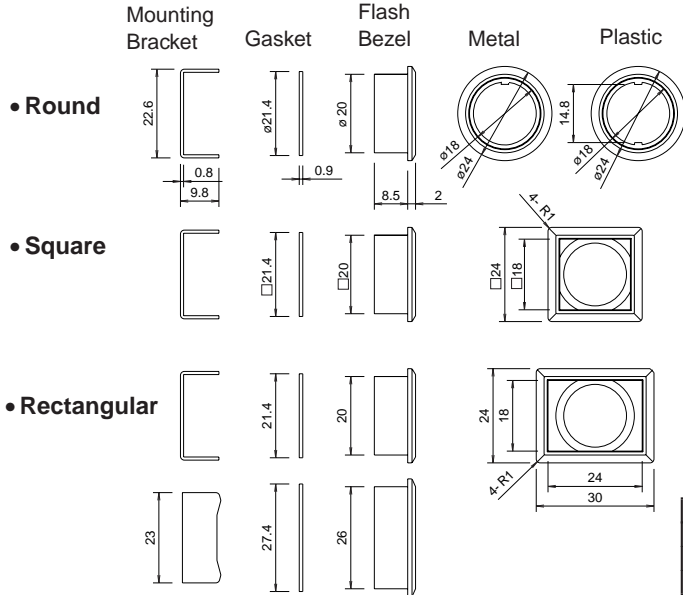

### [Flush Bezel with Control Units]

#### • L6 Series

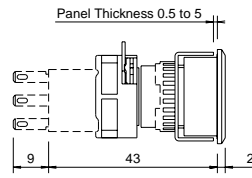

#### • A6 Series

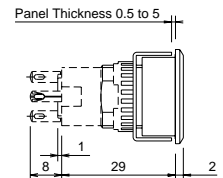

#### Selector Switch Illuminated Selector Switch

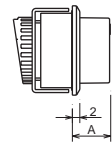

#### Key Selector Switch

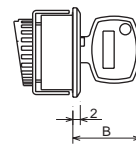

#### Lever Switch

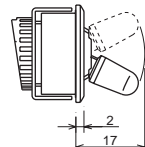

Unit	A (mm)
L6 selector switch	10.0
L6 illuminated selector	10.0
A6 selector switch	8.5

Unit	B (mm)
L6 key selector	18.1
A6 key selector	18.1

### [Mounting Hole Layout]

#### • Round

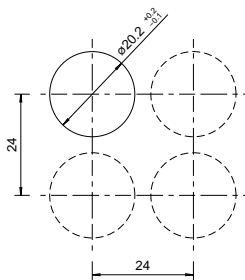

#### • Square

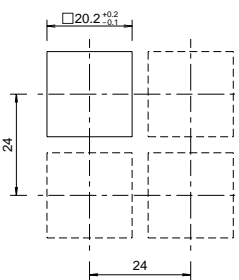

#### • Rectangular

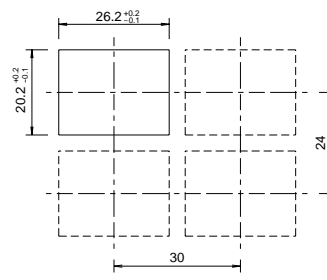

Mounting hole layout for the L6 series is the same for both straight-lever contact type and L-lever contact type.

### • Flush Bezel with Switch Guard

#### [L6 Series]

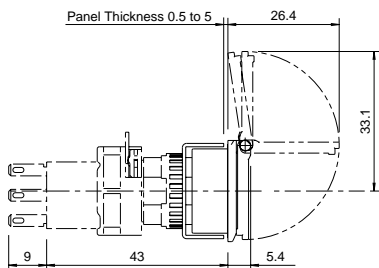

#### [A6 Series]

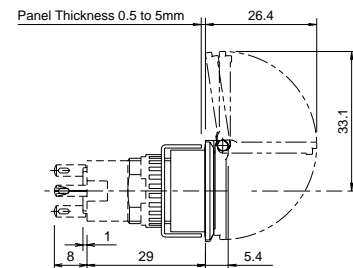

### [Mounting Hole Layout]

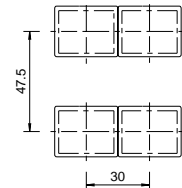

Mounting holes are the same size as rectangular flush bezels.

### • Mounting Hole Plug

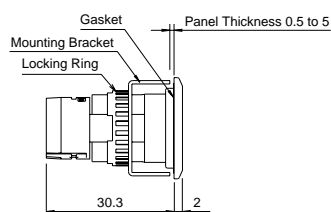

#### • Round

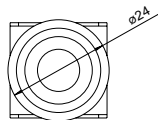

#### • Square

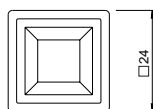

#### • Rectangular

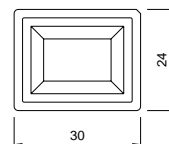

Mounting holes are the same size as flush bezels.

All dimensions in mm.

## Safety Precautions

- Turn off the power to the control units before starting installation, removal, wiring, maintenance, and inspection of the products. Failure to turn power off may cause electrical shocks or fire hazard.
- To avoid burning your hand, use the lamp holder tool when replacing lamps.
- For wiring, use wires of a proper size to meet the voltage and current requirements and solder correctly. Improper soldering may cause overheating and fire. Also, when using tab terminals, use appropriate quick connect receptacles.

## Instructions

### Panel Mounting of Flush Bezels

#### • L6 series

1. Remove the contact block from the operator. Remove the locking ring and anti-rotation ring. To remove the operator from the contact block, turn the locking lever in the direction opposite to the arrow on the housing.
2. Attach the flush bezel to the operator. Then insert the assembly into the panel. Attach the mounting bracket and tighten the locking ring. (Do not use the anti-rotation ring supplied with the operator.)  
For round flush bezels, place the projection on the bezel to the groove on the TOP side of the operator and mount onto the panel.
3. Insert the contact block, with the TOP markings on the contact block and the operator placed in the same direction. Then lock the units, turning the locking lever in the direction of the arrow.

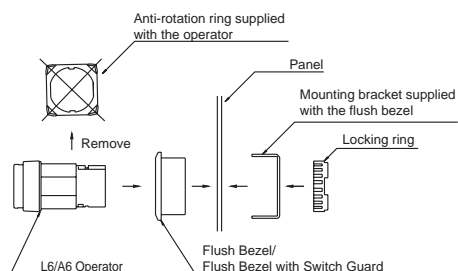

#### • A6 series

1. Remove the locking ring and anti-rotation ring from the operator.
2. Attach the flush bezel to the operator. Then insert the assembly into the panel. Attach the mounting bracket and tighten the locking ring. (Do not use the anti-rotation ring supplied with the operator.)  
For round flush bezels, place the projection on the bezel to the groove on the TOP side of the operator and mount onto the panel.

• For other instructions, refer to L6/A6 series catalogs.

### Panel Mounting of Flush Bezels with Switch Guard

For installation, see Panel Mounting of Flush Bezels.

### Replacing the Lens

#### • Removing

Remove the operator (lens, marking plate, and lens holder) from the operator by holding the lens removal tool (MT-101) and pull out.



#### • Installing

Insert the operator in the correct direction.

Die technischen Daten und sonstigen Beschreibungen dieser Druckschrift können ohne vorherige Ankündigung geändert werden.

## TREICHL - ATM Electronic

Auf der Bült 10 - 12  
D - 41189 Mönchengladbach

Telefon +49-2166/9585-45  
Telefax +49-2166/9585-47

E-Mail: atm@treichl.de  
Internet: www.atm-treichl.de

## L6 Series ø16mm Miniature Control Units

### Requires only a light touch. Collective mounting possible.

- Separate type control units with locking lever enable easy installation even when mounted collectively.
- Bright and clear illumination face. LED illumination.
- Gold (gold-clad silver) or silver contacts; SPDT or DPDT
- Degree of protection: IP65
- UL recognized and CSA certified (except buzzers)  
EN compliant (except buzzers)  
(EN60947-1, EN60947-5-1, TÜV Rheinland)

### Contact Ratings

#### • Gold-clad Contact

Maximum Voltage	250V AC/DC	
Thermal Current	3A	
Operating Voltage	30V DC	125V AC
Operating Current	0.1A (resistive load)	0.1A (resistive load)
Contact Material	Gold-clad silver	

#### • Silver Contact

Operating Voltage		30V	125V	250V	
Operating Current	AC 50/60Hz	Resistive Load	–	3A	2A
		Inductive Load	–	2A	1.5A
	DC	Resistive Load	2A	0.4A	–
		Inductive Load	1A	0.2A	–
Thermal Current		5A			
Contact Material		Silver			



### Major Specifications

- Mechanical Life Momentary: 2,000,000 operations  
Maintained, lever switch, selector switch: 250,000
- Electrical Life 100,000 operations
- Degree of Protection IP65 (IEC 62529)
- Terminal Style Solder/tab terminal type no. 110  
PC board terminal

## A6 Series ø16mm Miniature Control Units

### Light Duty, Short Unibody Type.

- Bright and clear illumination face. LED illumination.
- Gold (gold-clad silver) contacts; SPDT or DPDT
- Degree of protection: IP65 or IP40
- UL recognized and CSA certified. EN compliant

### Contact Ratings

Maximum Voltage		250V				
Thermal Current		3A				
Operating Voltage		12V	24V	110V	220V	
Operating Current	AC 50/60Hz	Resistive Load	–	–	1.0A	0.5A
		Inductive Load	–	–	0.7A	0.5A
	DC	Resistive Load	1.0A	1.0A	0.2A	–
		Inductive Load	0.7A	0.7A	0.1A	–
Contact Material		Gold-clad silver				



### Major Specifications

- Mechanical Life Momentary: 1,000,000 operations  
Maintained, pushlock turn reset: 250,000  
Selector switch, key selector switch: 50,000
- Electrical Life Maintained: 50,000 operations  
Others: 100,000 operations  
(1,200 operations /hour)
- Degree of Protection IP65 (waterproof/oiltight type)  
IP40 (enclosed type)
- Terminal Shape Solder/tab terminal type no. 110

Die technischen Daten und sonstigen Beschreibungen dieser Druckschrift können ohne vorherige Ankündigung geändert werden.

## TREICHL - ATM Electronic

Auf der Bült 10 - 12  
D - 41189 Mönchengladbach

Telefon +49-2166/9585-45  
Telefax +49-2166/9585-47

E-Mail: atm@treichl.de  
Internet: www.atm-treichl.de

www.atm-treichl.de